

table of contents

Full product index on pg.157



servicing artists for over 30 years....

Woolfitt's opened its doors in 1978 in downtown Toronto on Dupont Street. Through the years, the company has evolved from its beginnings as a school and picture framing business to a full service artists' materials business.

Shortly after launching the business, Woolfitt's began specializing in fine art papers. The selection of papers made available to the consumer is still unsurpassed in Canada to this day.

After over 30 years of service, Woolfitt's Art Enterprises is known as one of Canada's leading distributors of artist's materials, fine art papers, boards, brushes, stretched canvas, paints, and frames.

order by fax:

24 hours a day to
416-536-4322

telephone:

1-800-490-3567 or
416-536-7878 Ext. 29

or e-mail:

contact@woolfitts.com
or djenep@woolfitts.com

WOOLFITT'S

2010 catalogue

frames

Frames	4
Mat Boards	6
Framing Supplies	7

paper

Paper Usage Chart	10
Glossary of Paper Terms	11
Watercolour Paper - sheets ...	12
Watercolour Paper - blocks.....	13
Watercolour Paper - Pads	15
Printmaking Paper.....	17
Book Paper	18
Drawing/All Purpose Paper.....	20
Specialty Paper	21
Digital & Photo Paper	22
Paper Rolls	24
Coloured & Decorative Paper..	26
Japanese Paper.....	27
Sketch Books & Pads.....	28
Board.....	33
Displays & Assortments	34

acrylic paint & mediums

Acrylic Paint	36
Colour Charts	42
Acrylic Mediums	52
Assortments & Displays	54

oil paint, modifiers & grounds

Oil Paint	56
Water Mixable Oil Paint	63
Oil Sticks	64
Alkyd Paint	64
Modifiers & Grounds	65
Assortments & Displays	68

watercolour paint & mediums

Watercolour Paint	70
Gouache & Tempera	74
Mediums	75
Assortments & Displays	76

woolfitt's art enterprises

1153 Queen Street West • Toronto, Ontario • M6J 1J4
Tel. 416-536-7878 or 1-800-490-3567 • Fax. 416-536-4322

retail: 416-536-7878 x.30 or contact@woolfitts.com
sales - wholesale: 416-536-7878 x.27 or bkievit@woolfitts.com

www.woolfitts.com

painting tools

Brushes	78
Assortments & Displays	91
Painting Knives	93
Painting Accessories	94
Canvas & Painting Supports ..	96
Easels	101

drawing

Pens & Markers	106
Pen & Ink	119
Pencils	120
Charcoal	125
Drawing Accessories	127
Erasers	127
Pastels & Crayons	128
Assortments & Displays	134

printmaking

Inks	136
Screenprinting.....	137
Modifiers & Grounds	138
Etching, Lino & Litho.....	139

necessary accessories

Portfolios & Albums	142
Archival Storage & Supplies ..	144
Bookbinding	146
Adhesives & Fixatives.....	148
Tape	150
Cutting Tools	151
Drafting & Rulers	153
Sculpture	154
Miscellaneous Art Supplies....	155
Books.....	156

frames

paper

acrylic paint & mediums

oil paint & modifiers

watercolour paint & mediums

painting tools

drawing

printmaking

necessary accessories



WOOLFITT'S

service policy

returned goods

Materials returned will be subject to a 15% restocking charge. Returns require prior authorization and a RMA number from Customer Service.

We cannot accept returned goods if:

1. Material has been opened or is not in the original packaging.
2. Goods are not in saleable condition.
3. Goods were a custom order, cut to size or non-stocked.
4. Goods were purchased more than 30 days from date of return.
5. All material returned is subject to inspection before a credit is approved.
6. Goods returned without an RMA number will be returned at customer's expense.

privacy policy

At Woolfitt's, we respect the privacy of our clients and we are committed to keeping your personal information accurate, confidential, secure and private.

ordering

To help ensure proper processing of your order, please be sure to include your account number, the item code, quantity and a full description of the item. Wherever possible, please try to order in standard packs as it reduces the possibility of damaged goods. Special order items must be ordered in standard packs.

packing charge for oversized items

Due to the high cost of packaging materials a packing charge of \$12.00 will be applied to broken packs of 40 x 60" matboard and foam board and to broken packs of pre-stretched canvas over 36 x 54". We are unable to break packages of 48 x 96" or larger of matboard or foamboard, or pre-stretched canvas over 48 x 72" because of potential shipping damage. This does not apply to customer pick-ups at our location.

credit accounts

Initial orders are COD or can be paid by credit card (Mastercard, Visa and American Express) until an account is established. Woolfitt's offers 30-day terms to customers once a credit application has been received and approved. In order to speed up the approval process, references that will reply by phone or fax are preferred. All orders are subject to approval by our credit department. Customers will be advised if an order cannot be shipped.

freight carriers

All orders are shipped freight pre-paid and billed, unless otherwise requested. Shipments will go by the most dependable and economic carrier of our choice. Any special freight requested (i.e. next day air) will be charged to the customer.

standard packs

It is preferable to place an order in full packs. Standard pack sizes are listed with the item description.

damage claims

Woolfitt's takes extra care in packaging your order. Should goods arrive damaged, do the following:

1. Prepaid & Charge Freight

All waybills should be stamped subject to count and inspection as hidden damage can occur. If the merchandise is obviously damaged make a note on the waybill that the shipment was received damaged. Send proof to Woolfitt's within 10 days so that we can contact the carrier to initiate a claim. Do not return goods unless authorized to do so. We will not accept claims reported beyond a 10-day period from the receipt of the order.

2. Collect Shipments

Make a note on the waybill at the time of delivery that the shipment was received damaged and file your damage claim immediately with the delivering carrier. Do not return damaged goods to us.

terms

Net 30 days from date of invoice. Accounts that are unpaid after 30 days are subject to a 1 1/2% monthly service charge. Accounts over 45 days will be put on credit hold.

pricing

All prices shown are suggested list prices (unless otherwise noted). Prices are subject to change without notification.



frames & mat board



The Q Seal stands for Quality!!!

At Woolfitt's our goal is to provide the highest quality products at the best possible price. Very often, when we need products to meet our criteria, we have them custom manufactured to our stringent standards.

This is the case with our Q Frames. Ben Woolfitt, our founder and an eminent artist in his own right, seeking superior quality frames, designed and developed these hand made Q Frames for Woolfitt's. The first thing a trained eye will note are the hand-finished corners with exceptional fit and strength. The solid construction and precise dimensions of each frame are complemented by the elegant styling.

Q gallery frames

The Q Gallery Frames are designed exclusively by Woolfitt's to meet the highest quality workmanship and material standards. The flat profile and nicely finished corners suit a wide variety of art work and come fitted with glass and mount hooks. These 3/4" flat profile frames are deep enough to hold paintings mounted on standard depth stretcher bars, but come fitted with glass so they can be also used for art works on paper and for creating shadow box frames. The solid wood body and precise dimensions of each frame are made in six beautiful and versatile colours, ranging from a modern matte black, stylish brown black, rich cherry red, a light and natural wood grain, to the slightly distressed, hand leafed antique gold and silver. The luxurious finishes lend any presentation a gallery-ready elegance.

Q gallery frame section

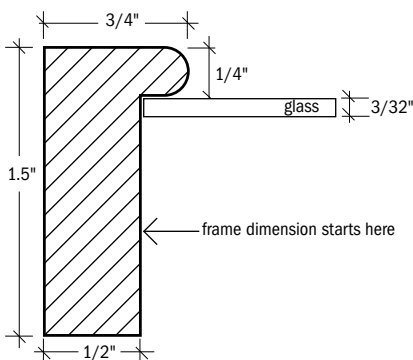

Size	Black	Brown Black	Red	Natural	Pk	List/Ea.
6 X 6"	F0606B	F0606BB	F0606R	F0606N	12	14.90
8 X 10"	F0810B	F0810BB	F0810R	F0810N	12	21.25
9 X 12"	F0912B	F0912BB		F0912N	12	23.65
11 X 14"	F1114B	F1114BB		F1114N	12	28.40
12 X 12"	F1212B	F1212BB		F1212N	12	26.85
12 X 16"	F1216B	F1216BB		F1216N	12	30.90
16 X 16"	F1616B	F1616BB		F1616N	12	36.65
16 X 20"	F1620B	F1620BB		F1620N	12	40.40
18 X 24"	F1824B	F1824BB		F1824N	12	47.75
22 X 30"	F2230B				6	75.55

Size	Antique Gold	Antique Silver	Pk	List/Ea.
6 X 6"	F0606G	F0606S	12	18.35
8 X 10"	F0810G	F0810S	12	26.15
9 X 12"	F0912G	F0912S	12	29.10
11 X 14"	F1114G	F1114S	12	34.95
12 X 12"	F1212G	F1212S	12	33.05
12 X 16"	F1216G	F1216S	12	38.05
16 X 16"	F1620G	F1620S	12	49.70
16 X 20"	F1824G	*F1824S	12	58.75

Q mini gallery frames

Q Mini Gallery frames give a lighter touch for more delicate pieces. Minis have all the quality features of a Gallery frame but with a narrower profile and less depth. The Mini Gallery frame is available only in black and is fitted with glass and mount hooks.

Item #	Size	Pk	List/Ea.
F0406BM	4 X 6"	12	10.45
F0507BM	5 X 7"	12	12.25
F0810BM	8 X 10"	12	15.35
F0912BM	9 X 12"	12	18.30
F1114BM	11 X 14"	12	24.90
F1216BM	12 X 16"	12	27.75
F1620BM	16 X 20"	12	36.55

Q mini gallery frame section

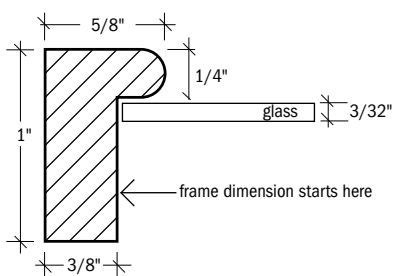

Q document frames

These solid wood document frames are great to accent any home or office. Contemporary and bold, the Q Document frames have the same finished edges as the Q Gallery Frames in a smaller profile and come in a solid black finish with glass and mount hooks.

Q document frame section

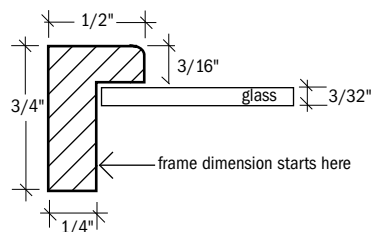

Item #	Size	Pk	List/Ea.
F8511BD	8.5 X 11"	12	14.70
F0810BD	8 X 10"	12	13.50
F1114BD	11 X 14"	12	15.55
F1216BD	12 X 16"	12	20.10

Maidstone

MUSEUM MAT BOARD

BUFFERED WITH CALCIUM CARBONATE

100% COTTON

BLEED, SCUFF & FADE RESISTANT

NEUTRAL pH

NO RESIDUAL METALS OR ALUM

A good mat board will enhance a framing composition while protecting it. Maidstone Museum Mounting Board does that! Maidstone Museum Mounting Board is a solid-core 100% rag board which is acid-free, buffered with calcium carbonate and is scuff and fade resistant. Available in 2, 4 and 8 ply for your archival framing requirements

Item#	Description	NET
MM3240W-1	White 32 x 40" 1 Ply (Barrier Paper)	1.70
MM3240W-2	White 32 x 40" 2 Ply	3.70
MM3240W-4	White 32 x 40" 4 Ply	5.95
MM3240W-8	White 32 x 40" 8 Ply	17.50
MM4060W-2	White 40 x 60" 2 Ply	6.25
MM4060W-4	White 40 x 60" 4 Ply	10.95
MM4060W-8	White 40 x 60" 8 Ply	26.18
*MM60104W-4	White 60 x 104" 4 Ply	60.00
PM3240-4	White UNBUFFERED 32 x 40" 4 Ply	6.05
MM3240WW-4	Warm White 32 x 40" 4 ply	5.95
MM4060WW-4	Warm White 40 x 60" 4 Ply	10.95
MM3240A-4	Antique White; 32 x 40"; 4 Ply	6.50
MM4060A-4	Antique White; 40 x 60"; 4 Ply	14.75
MM3240N-4	Natural 32 x 40" 4 Ply	4.99
MM4060N-4	Natural 40 x 60" 4 Ply	11.43
MM3240Z-4	Zinc 32 x 40" 4 Ply	5.00
MM4060NG-4	Grey 40 x 60" 4 Ply	5.98

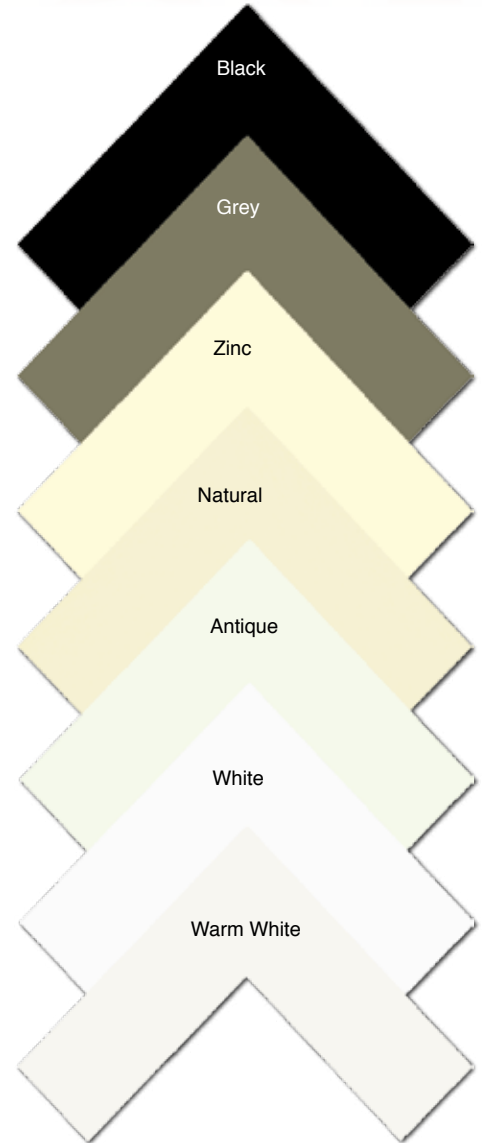

conservation board

A non-rag, acid-free mat board for all framing where museum mounting is not required. A solid core eliminates the problem of contrasting levels. Maidstone buffered Conservation Board comes in 2 and 4 ply thicknesses.

C4060SW-4	Snow White 40 x 60" 4 Ply	7.75
-----------	---------------------------	------

pre-packed mat board

Not only the perfect board for all your framing and matting needs, but also handles beautifully for architectural and scale model drawings!

Item#	Description	NET
MM1620	16 x 20"; NEUTRAL GREY; PACK OF 4	6.49
MM1220	12 x 20"; NEUTRAL GREY; PACK OF 4	5.99
MM1620	16 x 20"; NATURAL; PACK OF 4	6.49
MM1620	16 x 20"; BLACK; PACK OF 4	6.49
MM1620	16 x 20"; WHITE; PACK OF 4	6.49
MM1620	16 x 20"; WARM WHITE, PACK OF 4	6.49

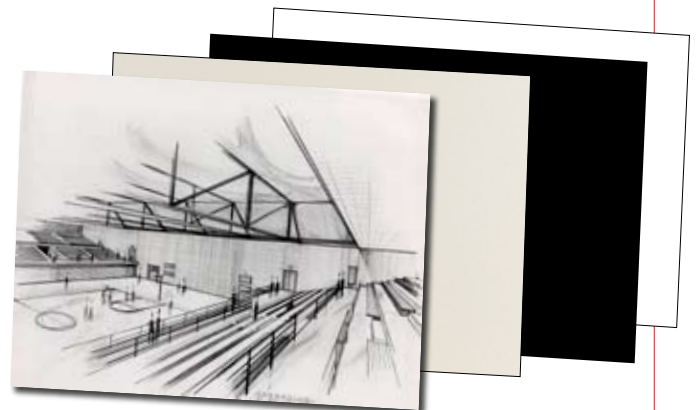

mi-teintes art and framing board

Mi-Teintes Art and Framing Board is a multi-purpose museum quality matboard available in artists' colors. Mi-Teintes Art Boards are created from actual fine art pastel papers attached to museum quality matboard. Each sheet of Mi-Teintes matboard has a richly colored front face, a white core and white backing making it an extremely versatile art and framing board for smaller projects. Acid free.

Mi-Teintes Framing Board – 16 X 20"

Item #	Colour	Pk	List/Ea.
199-6400	Azure #102	5	4.70
199-6410	Bisque #502	5	4.70
199-6409	Blue #495	5	4.70
199-6411	Burgundy #503	5	4.70
199-6435	Champagne #470	5	4.70
199-6432	Cream #407	5	4.70
199-6438	Dark Blue #500	5	4.70
199-6405	Dark Grey #345	5	4.70
199-6402	Egg Shell #112	5	4.70
199-6434	Felt Grey #429	5	4.70
199-6427	Flannel Grey #122	5	4.70
199-6414	Indigo Blue #140	5	4.70
199-6401	Ivory #111	5	4.70
199-6408	Ivy #448	5	4.70
199-6437	Light Blue #490	5	4.70
199-6436	Light Green #480	5	4.70
199-6433	Moonstone #426	5	4.70
199-6430	Oyster #340	5	4.70
199-6425	Pale Yellow #101	5	4.70
199-6404	Pearl #343	5	4.70
199-6426	Pearl Grey #120	5	4.70
199-6428	Red Earth #130	5	4.70
199-6412	Royal Blue #590	5	4.70
199-6429	Sand #336	5	4.70
199-6431	Sky Blue #354	5	4.70
199-6406	Stygian Black #425	5	4.70
199-6407	Steel Grey #431	5	4.70
199-6439	Tobacco #501	5	4.70
199-6413	Twilight #131	5	4.70
199-6403	White #335	5	4.70



logan complete guide to home picture framing

92 pages of illustrated instruction on mat cutting and making frames plus sections on mounting, glazing and display techniques.

Item #	Size	Pk	List/Ea.
F245	Complete Guide to Framing	1	19.50



linco mounting hinging tissue

Self-adhesive hinging tissue has adequate strength to hinge medium sized art. Pressure sensitive acrylic adhesive is permanent, non-yellowing, acid and lignin free, and virtually disappears when burnished.

Item #	Size	Pk	List/Ea.
L533-0125	1" X 400"	1	23.25
L533-0126	1" X 1176"	1	40.05



lineco museum mounting kit

Mount your prized artwork with the same system used and trusted by museum professionals. Kit contains acid free, preservation quality mounting materials: Japanese Hinge Paper, Pure Wheat Starch Adhesive, Blotters and Separators, Linen Cloth Tape, and Complete Instructions.

Item #	Pk	List/Ea.
L533-2000	1	40.45



fletcher framers' points

Designed to fire framing points quickly and easily. When using the flexi-points, an added convenience is being able to remove and replace materials from the frame without having to replace the points.

Fletcher Point Drivers

Item #	Description	Pk	List/Ea.
07-700	Fleximaster Point Driver	1	304.90
07-500	Framemaster Point Driver	1	262.00

Fletcher Points – 5/8"

Item #	Description	Pk	List/Ea.
08-955	Flexi Points – 3 700 per Box	1	52.60
08-950	Framers Points – 3 000 per Box	1	44.00

glazier points

Use to hold glass in place, when framing with wooden frames. Their T-shape makes them easier to use than most glazier points, because they can be inserted with a putty knife or flat head screw driver and don't require a framing gun or other tools.

Item #	Description	Pk	List/Ea.
585	*#7; 85 Pieces	1	3.85

* Available by special order

frame sealing tape

Pressure sensitive adhesive. Use for sealing raw wood, fillets, rabbets, frame backs and frame packages. Acid-free.

Item #	Size	Colour	Pk	List/Ea.
L387-0151	1.25" X 1000"	Grey	1	26.25



Braided picture wire

braided picture wire

Wire made of twelve braided strands, will support up to 20 lbs. of weight.

Item #	Description	Pk	List/Ea.
34-2	#2 - 12 Strand, 15'	1	3.95

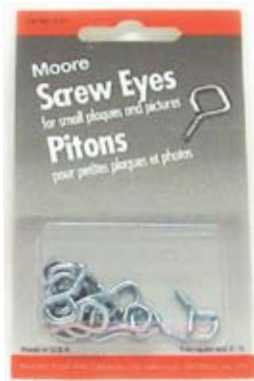

Screw eyes

screw eyes

Ideal for hanging small plaques and pictures.

Item #	Description	Pk	List/Ea.
131-4	16 pieces, Small	1	2.10

picture mount tape

Double faced adhesive tape is great for hanging items on glazed brick, glass, tile, or metal surfaces. Also useful for keeping pictures mounted with regular picture hangers straight.

Item #	Size	Pk	List/Ea.
67	1/2" X 80"	1	4.90

exhibition "L" pins

An easy answer to short-term hanging! Chrome-plated pins secure glass and matted prints to the wall without bending. Size: 1" long; 3/8" bend; 1/16" diameter. Do not use on hard wall surfaces such as plaster. Excellent tool for galleries and museums that change exhibits often.

Item #	Description	Pk	Net
L2465	Box of 100	1	20.20

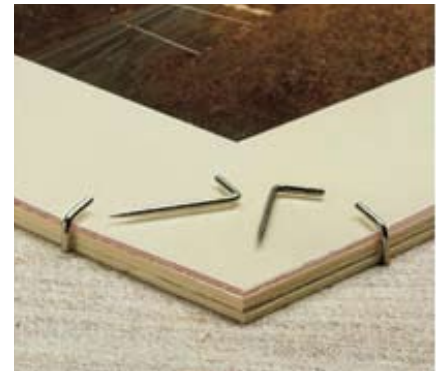

Exhibition "L" Pins

protect-o buttons

Use these small clear self-adhesive buttons to protect floors, tables, walls and more. Especially useful for the back of framed artworks.

Item #	Description	Pk	List/Ea.
42C	8 pieces, Self Adhesive	1	2.00



Protect-o buttons

picture hangers

An easy way to hang pictures, plaques and mounted items securely and inexpensively. Easy to install with an ordinary hammer and works equally well on materials ranging from hardboard to softwood.

Picture Hangers

Plated steel hooks with tempered steel nails.

Item #	Description	Pk	List/Ea.
24J	10 lbs. 10 pack	1	1.65
25J	20 lbs. 10 pack	1	1.65
26J	30 lbs. 10 pack	1	1.65
221	Naillless Sawtooth 4 pack	1	2.25
10C	Naillless 2 in 1	1	2.60

Picture Hanger With Super Nail

Constructed from tempered steel, then given a needle sharp point. Almost effortless hammering into plastic or wood.

Item #	Description	Pk	List/Ea.
227	50 lbs. - 2 pieces	1	3.40

Sharks' Tooth Hangers

These hangers make hanging items mounted on hardboard, particle board and hard or soft wood easy. Simply hammer the sharks tooth into the back of the item, bend outward at the score line and place over a nail or screw.

Item #	Description	Pk	List/Ea.
522	2 piece set	1	2.70

Hinge Hanger

Item #	Description	Pk	List/Ea.
203	Small, 4 pieces	1	2.70

Utility Hangers

Item #	Description	Pk	List/Ea.
206	4 pieces	1	2.90



Picture hangers